



EISSN: 2788-9920  
NTU Journal for Renewable Energy  
Available online at:  
<https://journals.ntu.edu.iq/index.php/NTU-JRE>



## Design and Implementation of multi-level inverter for PV system with various DC Sources

Hameed G. Juma'a<sup>1</sup>, Thamir H. Atyia<sup>1</sup>

<sup>1</sup>Electrical Department/ Engineering College/Tikrit University /Tikrit, Iraq

### Article Information

Received: 03 – 07 - 2023

Accepted: 24 – 07 - 2023

Published: 01 – 08 – 2023

### Corresponding Author:

Thamir H. Atyia

### Email:

[dr.thamir.atyia@tu.edu.iq](mailto:dr.thamir.atyia@tu.edu.iq)

### Key words:

SPWM, Low THD, Multilevel inverter, Less power switching devices.

### ABSTRACT

Multilevel inverters h-bridge (MLI) are now favored over conventional transformers due to higher output voltage levels and lower harmonic distortions. In this study, a 45-level and 39-level inverter with lower power switchgear number was constructed. The 16-switch single-phase MLI inverter is generated, simulated, and used realistically. The simulation system uses a control method called sinusoidal pulse width modulation (SPWM). The output voltage from the simulation includes total harmonic distortion (THD). THD values of 45 and 39 level output voltage simulation are 2.59% and 2.98% respectively. The system has been designed and tested practically without load, The THD value was 2.69% for 45-level and 3.13% for 39-level. These results demonstrate that the proposed MLI circuit and SPWM controller were successful in achieving the necessary voltage level and THD decreased when level increased.



**1. Introduction**

Energy from renewable energy systems such as solar, biofuel and a variety of other sources is widely used by power electronics equipment. Direct current (DC) is generated by renewable energy sources (RES). Inverters convert direct current (DC) power to alternating current (AC) power. Inverters produce waveforms with multiple harmonics as output. The MLI offers various advantages over a standard inverter, including decreased harmonics and greater output voltages. As a result, many scientists are working to create the greatest MLI circuits and controller algorithms possible in order to attain inexpensiveness, small footprints and excellent efficiency. As a result, MLI is more appropriate than traditional types for medium/high power industrial uses, The fundamental advantage of a multilevel inverter is that increasing the number of levels increases the output voltage and staircase waveform. The staircase waveform helps to reduce total harmonic distortion (THD) [1]. The cascaded H-bridge inverter is a novel type of MLI that produces greater levels of output voltage with fewest switches. It is simple to build and operate. Multilevel inverter topologies are divided into three categories: flying-capacitor, diode-clamped, and cascaded inverters. It has been used to control the cascaded H-bridge (CHB) for its flexibility and simplicity. There are two types of CHB inverter, symmetrical and asymmetrical topologies [2]. Cascaded MLIs are suited as separate-DC-sources for applications that utilize renewable energy like solar PV power plants [3]. Cascaded MLI is formed by sequentially connecting several single cell H-bridge inverters using various DC sources. Every inverter unit is configured to produce multiple output voltages (+Vdc, 0Vdc, and -Vdc) [4]. Optimizing MLI output voltage levels enhances system performance, lowers distorted signals, and certifies it for high-voltage workloads [5]. A multi-level inverter is an excellent choice for photovoltaic (PV) applications. It improves efficiency and power quality. PV panels with varying properties or irradianations can be employed as standalone DC sources in a cascaded H-bridge (CHB) multi-level converter. As a result, the difficult regulation of partially shaded PV converters can be handled [6], The nearest state control and multicarrier-based SPWM schemes are the most popular MLI applications because they reduce the number of switches and THD[7][8]. The implementation of a novel MLI topology with sophisticated controller is proposed in this study. The MLI practical set is implemented using an Arduino microcontroller set, and the results are validated using the MATLAB software platform. The goal of this research is to investigate the MLI with lower electronics switching devices and good power system

quality. This circuit is designed to provide various levels of output voltage with as little THD as possible. and to validate it using simulation and practical outcomes.

**2. THEORY OF MULTILEVEL INVERTERS**

For the conventional kind, 88 power electronic switching devices are needed to provide 45 levels of output voltage by connecting 22 cascade H-bridge voltage source inverters in series with 22 equal DC voltage sources [15]. In this study MLI 45 level need 4-Hbridge, and according to the relation  $3 \cdot h$ , where h is the bridge number, the highest level reachable is 81 levels and the values of the input voltages for each h-bridge are (1vdc, 3vdc, 9vdc, 27vdc), and if The number of bridges was 3, the highest level is 27 levels, and in the order of the voltage values for each bridge, as shown in Figure 1, and since the number of levels is equal to  $2S + 1$ , where S represents the algebraic sum of the input voltages for each bridge H, Can obtain any level Less than 81. By using this technology, the number of switches is reduced, thus reducing costs and losses, and increasing efficiency. For 45 level the inputs are (Vdc, 3Vdc, 9Vdc, and 9Vdc) and (Vdc, 3Vdc, 6Vdc, and 9Vdc) for 39 level. The switching pattern of the proposed MLI is described in Table (1) for 45-level. For example, to get 22Vdc according Table (1) the switches (S1, S2, S5, S6, S9, S10, S13, S14) are ON and others switches OFF. The same method is followed for the remaining output values. This table should be implemented in both the simulation program (Matlab) and the practical application. By reflecting the cases of switches in the positive part, the negative part can be achieved. For example, to get -22Vdc according Table (1) the switches (S1, S2, S5, S6, S9, S10, S13, S14) are OFF and others switches ON.

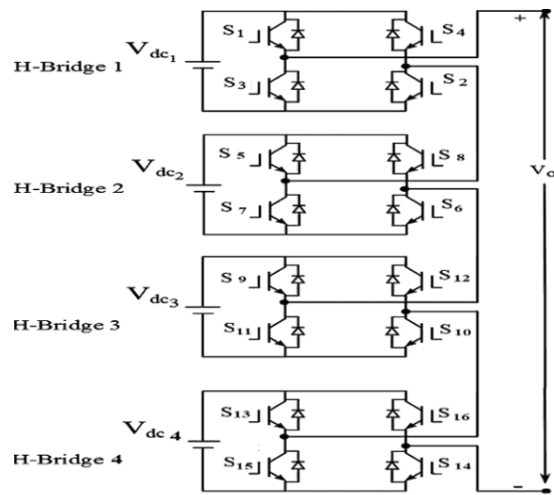

Figure (1): Suggested 45-level inverter circuit.

Table (1) Inverter output voltages and switching status

Levels	S1	S2	S3	S4	S5	S6	S7	S8	S9	S10	S11	S12	S13	S14	S15	S16
22V	1	1	0	0	1	1	0	0	1	1	0	0	1	1	0	0
21V	1	0	0	1	1	1	0	0	1	1	0	0	1	1	0	0
20V	0	0	1	1	1	1	0	0	1	1	0	0	1	1	0	0
19V	1	1	0	0	1	0	0	1	1	1	0	0	1	1	0	0
18V	1	0	0	1	1	0	0	1	1	1	0	0	1	1	0	0
17V	0	0	1	1	1	0	0	1	1	1	0	0	1	1	0	0
16V	1	1	0	0	0	0	1	1	1	1	0	0	1	1	0	0
15V	1	0	0	1	0	0	1	1	1	1	0	0	1	1	0	0
14V	0	0	1	1	0	0	1	1	1	1	0	0	1	1	0	0
13V	1	1	0	0	1	1	0	0	1	1	0	0	1	0	0	1
12V	1	0	0	1	1	1	0	0	1	1	0	0	1	0	0	1
11V	1	1	0	0	0	0	1	1	1	1	0	0	1	0	0	1
10V	1	1	0	0	1	0	0	1	1	1	0	0	1	0	0	1
9V	1	0	0	1	1	0	0	1	1	1	0	0	1	0	0	1
8V	0	0	1	1	1	0	0	1	1	1	0	0	1	0	0	1
7V	1	1	0	0	0	0	1	1	1	1	0	0	1	0	0	1
6V	1	0	0	1	0	0	1	1	1	1	0	0	1	0	0	1
5V	0	0	1	1	0	0	1	1	1	1	0	0	1	0	0	1
4V	1	1	0	0	1	1	0	0	1	0	0	1	1	0	0	1
3V	1	0	0	1	1	1	0	0	1	0	0	1	1	0	0	1
2V	0	0	1	1	1	1	0	0	1	0	0	1	1	0	0	1
1V	1	1	0	0	1	0	0	1	1	0	0	1	1	0	0	1
0V	1	0	0	1	1	0	0	1	1	0	0	1	1	0	0	1

**3. Configuration of the Proposed System**

The MATLAB application models the suggested system as depicted in Figure (2). The suggested system, represented is made up of a four PV solar systems with voltage (1:3:9:9V) for 45-level and (1:3:6:9V) for 39-level are recommended, where (V) is the input voltage value of the H-bridge cell. The total number of input sources was combined in the ratio (1:3:9:9V) to produce an output voltage with 45-levels (+22V to -22V).

**3.1. PV Module**

The photovoltaic power features, as shown in Figure (3), are nonlinear. The attributes of a PV cell are investigated using variables such as the voltage of the open circuit (Voc) and current through a short-circuit (Isc). The Isc, an irradiance-dependent quantity, is the maximum value of current that a cell may deliver. On the other side, The greatest voltage that a solar cell may produce when no current is flowing through it is known as Voc [9]. A common similar circuit

design exists to describe PV cells. Figure 4 depicts an individual diode with both series and shunt resistance. Photon-generated current (I<sub>ph</sub>) is created by PV and correlates to solar irradiation. Interface and connection-related losses are represented by resistance (R<sub>s</sub>), while diode leakage currents are expressed by parallel resistance (R<sub>sh</sub>) [10] [11].

**3.2. DC-DC converter**

A DC-DC step-up converter is required. Using the MPPT algorithm technique, the maximum generation power of the PV solar system can be achieved. To maximize output power in solar systems, several control approaches or strategies can be used [13]. The Perturb and Observe (P&O) method is used in this study, is the most widely used. It is commonly used in commercial PV inverters that use low-cost microprocessors due to the algorithm's simplicity and stability. Figure 3 depicts the (V-I) and (P-V) characteristics curves of the proposed PV systems. which is optimized according to the flow chart shown in Figure (5).

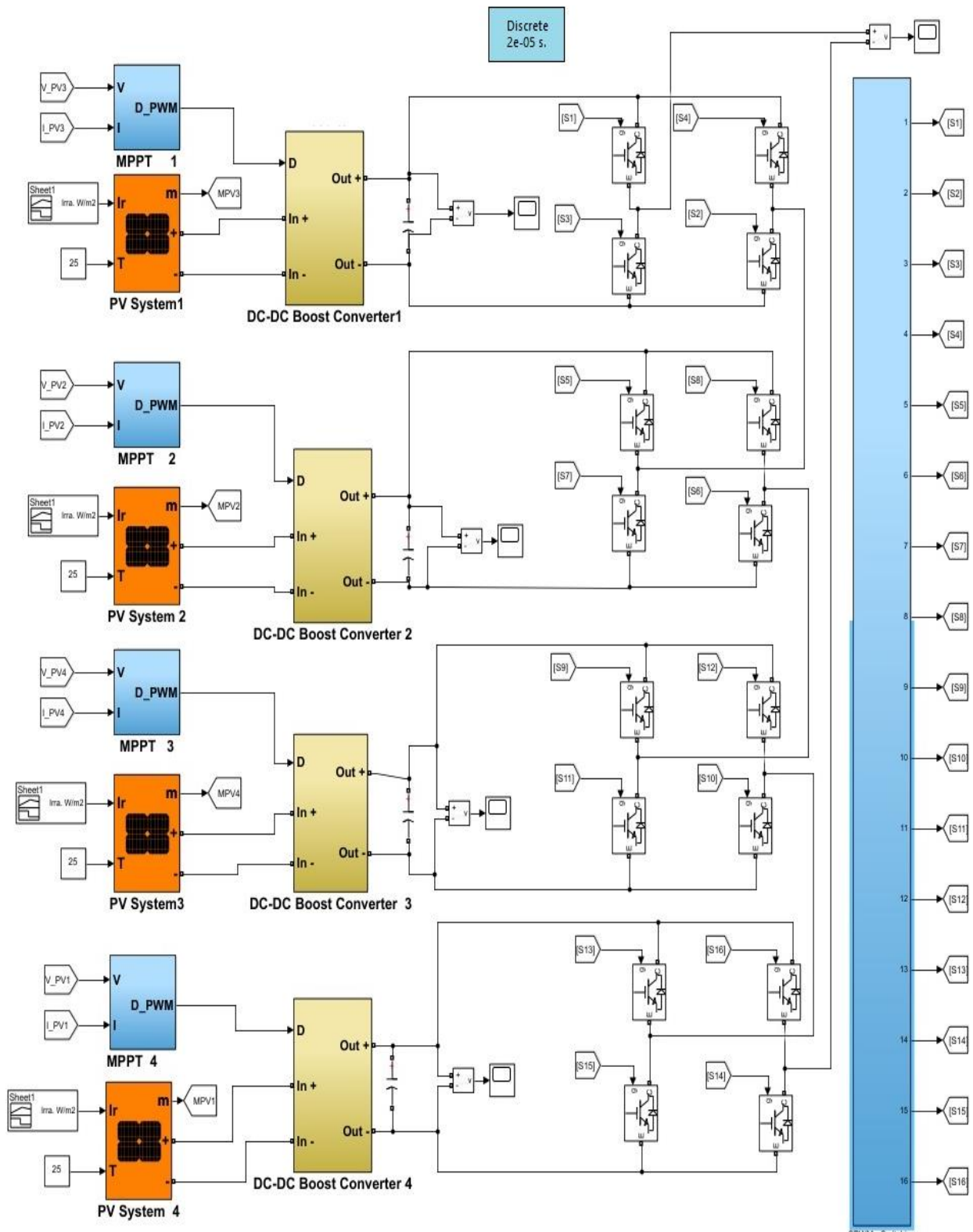

Figure (2): Modeling circuit of the proposed system with 45-voltage level

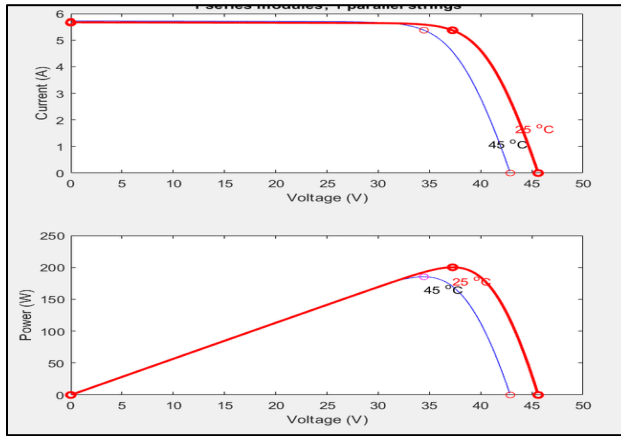

Figure 3: The (V-I) and (P-V) characteristics of a PV module [12].

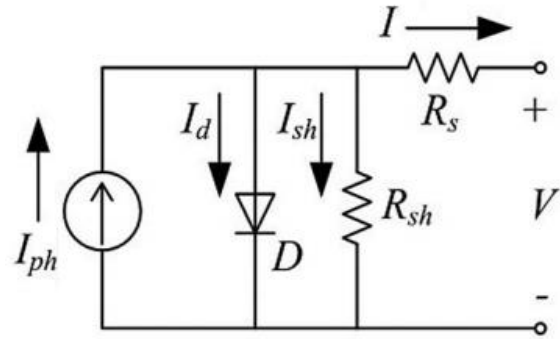

Figure 4: PV cell equivalent circuit [11].

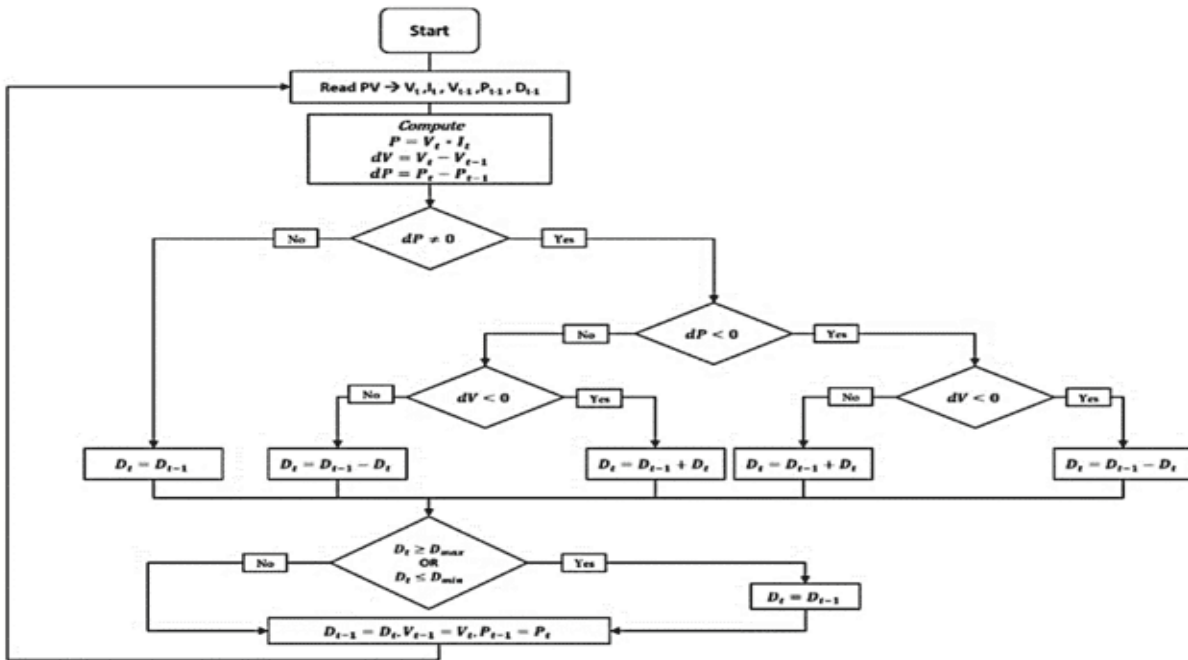

Figure (5): Flow Chart of the P&O technique [14].

### 3.3. Multilevel Inverter (MLI)

To provide distinct output voltages with varying levels, a multilevel inverter with uneven DC voltage source values and less power switching devices is used [15]. Various PWM approaches were utilized to drive the multilevel inverter switches. In this study, a Sine PWM (SPWM) controller proposed by [16] is improved to

provide output voltages of multilevel inverter. The multicarrier PWM utilized to generate a 45-volt level using a sine wave reference is depicted in Figure (6). The control circuit is built using the multicarrier PWM technique, as shown in Figure (7). To control the gate pulses, a simple PWM approach is used. A PWM pulse generator generates the gate pulses for the switches.



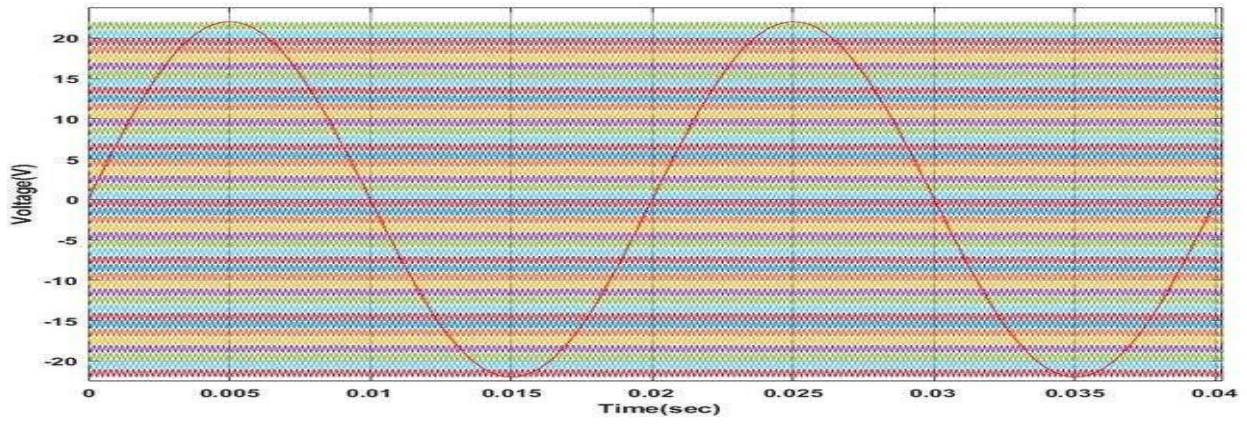

Figure (6): SPWM algorithm for 45- level inverter.

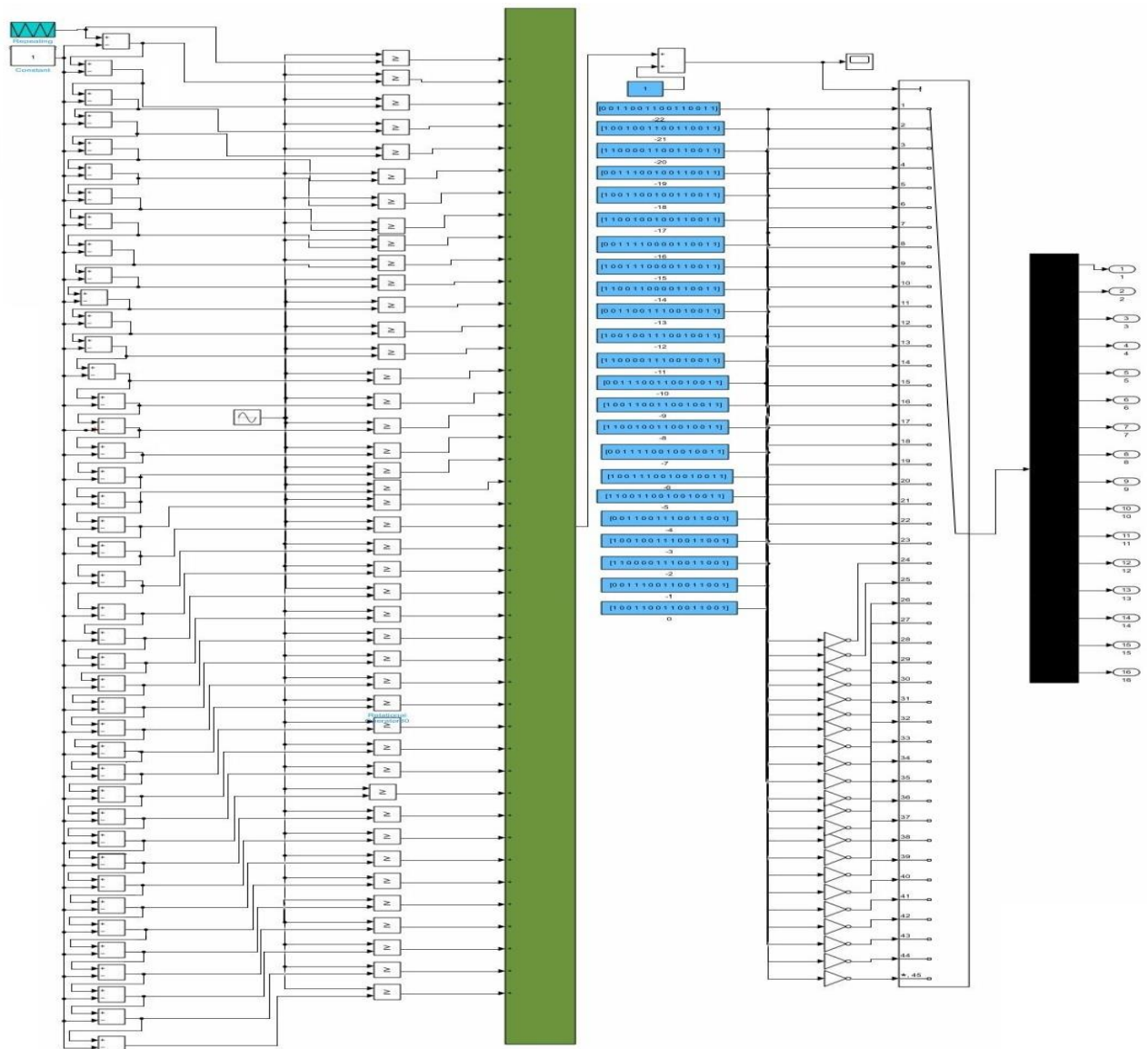
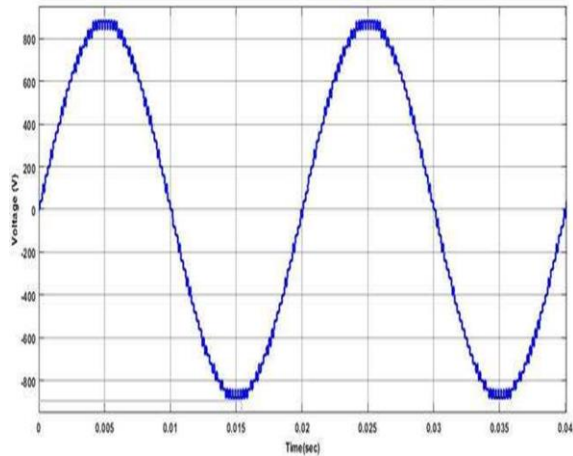

Figure (7): Modeling circuit of the suggested control system.

#### 4. Simulation Results

The proposed single-phase multilevel inverter is planned and reconstructed in MATLAB/Simulink using an SPWM controller and low-power electronics switching components. The DC input voltages for 45-level are set to (1, 3, 9, 9)V and (1, 2, 6, 9)V for 39-level with a carrier frequency of 5 kHz. Figure (8), depicts the output voltage waveform of a multilevel inverter. Figure (9) depicts the FFT spectrum of output voltage.



(a)

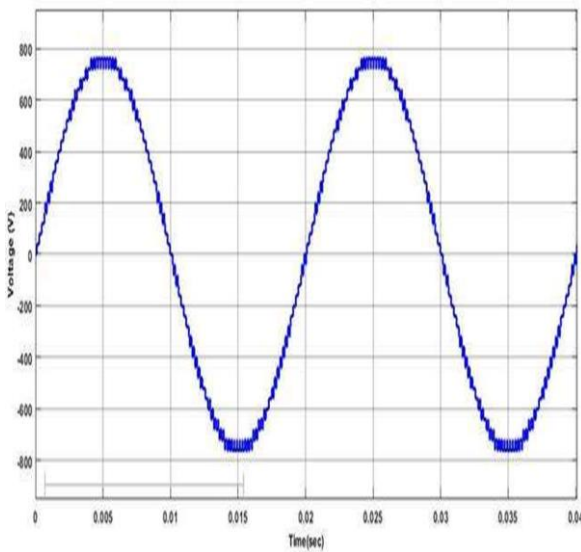

(b)

Figure (8): Output voltage at 5000 HZ (a) 45-level, (b) 39-level.

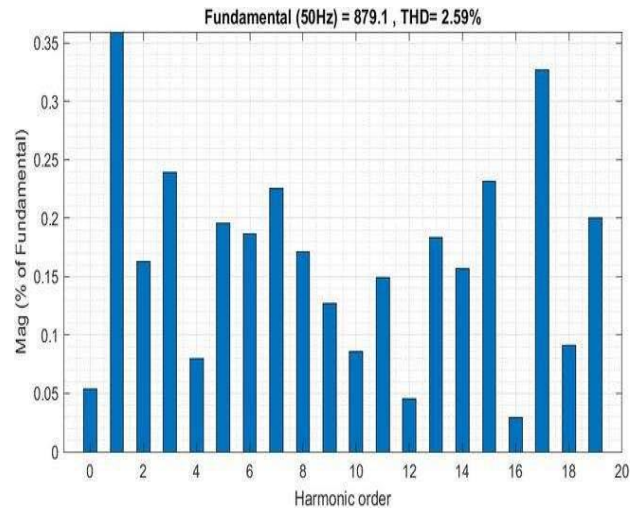

(a)

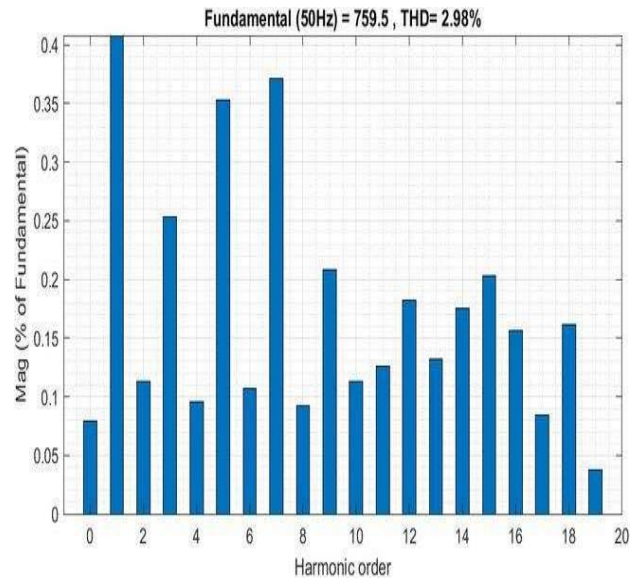

(b)

Figure (9): The FFT analysis of the output voltage (a) 45-level (b) 39-level.

#### 5. Practical results

In the course of our practical research, Arduino (MEGA 2560) was used to generate a series of successive pulses for the purpose of turning the switches ON and OFF, figure (10) shows a general block diagram of the REs 45-level system using the Arduino microcontroller, as shown in Table 1, to obtain the required levels starting from zero to +22 and to zero. This is for the positive part of the wave, then directly start with the negative part down to -22 then to zero. Thus, a full wave is a generated, this

process is repeated many times, as is appropriate to obtain a wave at a frequency of 50 Hz.

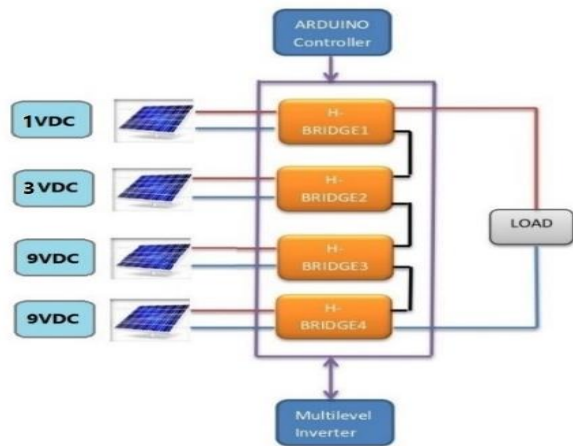

Figure (10): Block Diagram of the Proposed Controller 45-level.

Gate drive circuit based on TLP 250 Optocoupler shown in figure (11).

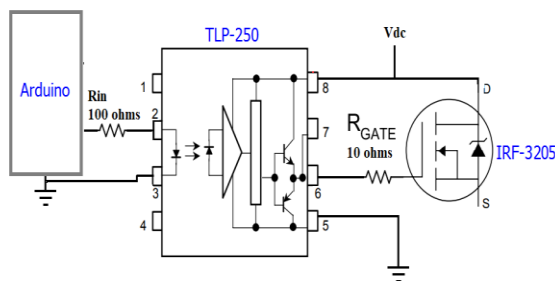

Figure (11): Gate drive circuit TLP 250 Optocoupler

A practical circuit consisting of four h-bridges was built and connected with voltage regulators and solar panels. By changing the voltage input values, we obtained the required levels. Figure (12), shows the connection of four solar cells with voltage regulators and a multi-level inverter. The MLI has several advantages over a typical inverter, including lower harmonics and higher output voltages, as well as lower cost and superior efficiency. As a result, MLI is more suitable than previous types for medium/high power industrial applications. Cascaded MLIs are suitable as separate-DC-sources for applications that utilise renewable energy, such as solar PV power plants.. Figure (13), represents an output voltage

wave at level 45 and 39 with no load. Figure (14); represent the THD value that was measured of output voltage practical circuit.

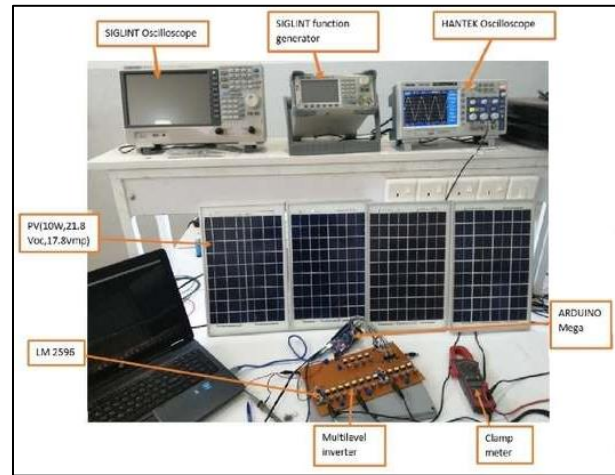
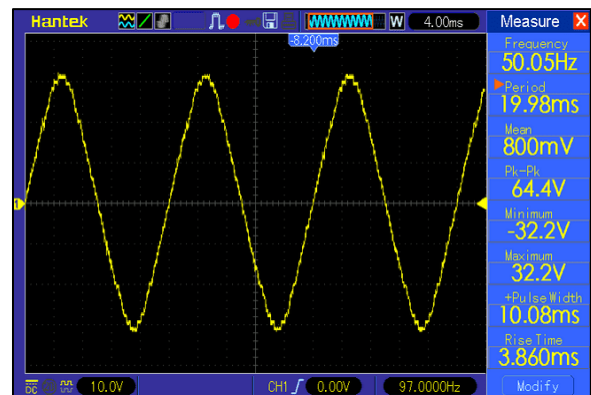
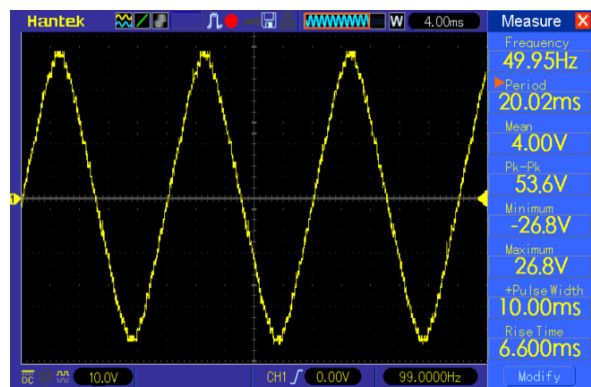

Figure (12): Prototype of practical research



(a)



(b)

Figure (13): Practical results of output voltage (a) 45-level, (b) 39-level.



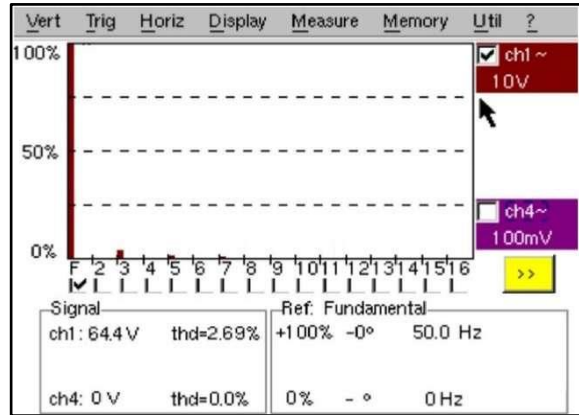

(a)

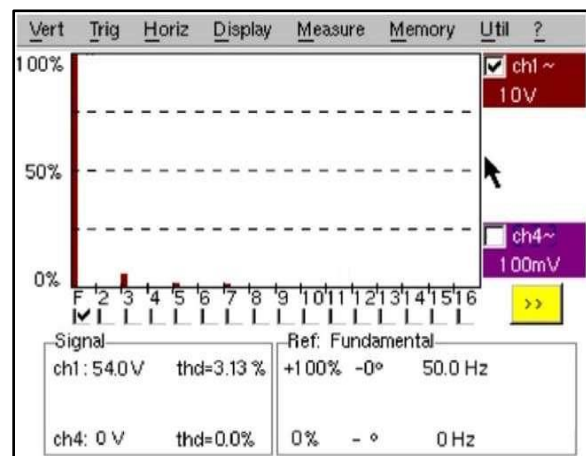

(b)

Figure (14): THD value of output voltage practical circuit (a) 45-level, (b) 39-level.

### Conclusions

This study suggests an MLI comprising 16 switches and 4 uneven DC input sources. This circuit's function is to show how well the SPWM controller works with the circuit. This circuit offers a lower THD value at greater output voltage levels. The proposed circuit's experimental setup has been constructed in the lab. Results from simulations and experiments clearly demonstrate that the THD is lower for 45-level than for 39-level. The suggested circuit's success at 45 and 39 is accompanied with a tolerable distortion rate, demonstrating that the system can operate at both levels with tolerable THD values. According to the simulation and experimental data, the THD value at 45-levels is lower than at 39-levels.

### References

- [1] M. Tayyab, M. Khairil, S. Marwangi, and M. M. Su'ud, "A review on harmonics elimination in real time for cascaded H-bridge multilevel inverter using particle swarm optimization," *International Journal of Power Electronics and Drive System (IJPEDS)*, vol. 12, no. 1, pp. 228-240, Mar 2021, doi: 10.11591/ijpeds.v12.i1.pp228-240.
- [2] Salman, Layth S., and Harith Al-Badrani. "Design and performance analysis of asymmetric multilevel inverter with reduced switches based on SPWM." *International Journal of Power Electronics and Drive Systems* 14.1 (2023): 320..
- [3] M. A. N. Doss, K. Mohanraj, S. Bhattacharjee, M. Tiwari, and D. Vashishtha, "Photovoltaic fed multilevel inverter using reverse voltage topology for standalone systems," *International Journal of Power Electronics and Drive System (IJPEDS)*, vol. 10, no. 3, pp. 1347-1354, Sep. 2019, doi: 10.11591/ijpeds.v10.i3.pp1347-1354.
- [4] A. Bughneda, M. Salem, A. Richelli, D. Ishak, and S. Alatai, "Review of Multilevel Inverters for PV Energy System Applications," *Energies*, vol. 14, no. 6, 2021, doi: 10.3390/en14061585.
- [5] R. K. Antar, B. M. Saied, and R. A. Khalil, "Using seven-level cascade H-bridge inverter with HVDC system to improve power quality," *First National Conference for Engineering Sciences (FNCES2012)*, Baghdad, Iraq IEEE, 2012, doi:10.1109/NCES.2012.6740457.
- [6] Bakhshizadeh, Mohammad Kazem, Hossein Iman-Eini, and Frede Blaabjerg. "Selective harmonic elimination in asymmetric cascaded multilevel inverters using a new low-frequency strategy for photovoltaic applications." *Electric Power Components and Systems* 43.8-10 (2015): 964-969.
- [7] C.-H. Hsieh, T.-J. Liang, S.-M. Chen, and S.-W. Tsai, "Design and implementation of a novel multilevel DC-AC inverter," *IEEE Transactions on Industry Applications*, vol. 52, no. 3, May/June 2016, doi: 10.1109/TIA.2016.2527622.
- [8] TUMMALA, Suresh Kumar, et al. Comparison of Control Techniques & Modeling of 15-level cross H Bridge Multilevel Inverter. In: *E3S Web of Conferences*. EDP Sciences, 2023. p. 01174.
- [9] KILLAM, Alexander C., et al. Monitoring of photovoltaic system performance using outdoor Suns-VOC. *Joule*, 2021, 5.1: 210-227.

- [10] Gopi, R.R.; Sreejith, S. Converter topologies in photovoltaic applications—A review. *Renew. Sustain. Energy Rev.* **2018**, *94*, 1–14. doi: [10.1016/j.rser.2018.05.047](https://doi.org/10.1016/j.rser.2018.05.047)
- [11] Ibraheem Alnaib, Ahmed MT. "Simulation and Characteristics Study of Solar Photovoltaic Array using Matlab/Simulink." *Journal of Techniques* **29.1** (2016).
- [12] Abadi, Imam; Uyuniyah, Qurrotul; Nur Fitriyanah, Dwi; Jani, Yahya; Abdullah, Kamaruddin; Hendroko Setyobudi, R.; Danang Birowosuto, M.; Kala Mahaswa, R.; Jani, Y.; Vincã“viã• a-Gaile, Z. (2020). Performance Study of Maximum Power Point Tracking (MPPT) Based on Type-2 Fuzzy Logic Controller on Active Dual Axis Solar Tracker. *E3S Web of Conferences*, **190**, 00016. doi: [10.1051/e3sconf/202019000016](https://doi.org/10.1051/e3sconf/202019000016)
- [13] Salman, S., AI, X. & WU, Z. Design of a P-&-O algorithm based MPPT charge controller for a stand-alone 200W PV system. *Prot Control Mod* .
- [14] Shaqour, Ayas; Farzaneh, Hooman; Yoshida, Yuichiro; Hinokuma, Tatsuya (2020). Power control and simulation of a building integrated stand-alone hybrid PV-wind-battery system in Kasuga City, Japan. *Energy Reports*, **6**(1), 1528–1544. doi: [10.1016/j.egy.2020.06.003](https://doi.org/10.1016/j.egy.2020.06.003)
- [15] Al-Badrani, Harith, Rakan Khalil Antar, and Asef A. Saleh. "Modeling of 81-Level Inverter Based on a Novel Control Technique." *Przeglad Elektrotechniczny* **98.3** (2022). doi: [10.15199/48.2022.03.13](https://doi.org/10.15199/48.2022.03.13)
- [16] K. Suresh and E. Parimalasundar, "A Modified Multi Level Inverter With Inverted SPWM Control," in *IEEE Canadian Journal of Electrical and Computer Engineering*, vol. 45, no. 2, pp. 99-104, Spring 2022, doi: [10.1109/ICJECE.2022.3150367](https://doi.org/10.1109/ICJECE.2022.3150367).